



HIGH PRODUCTIVITY ALUMINUM WHEEL PROCESSING TURNING CENTER

# PUMA AW II

560/MF II • 660 II



**DN SOLUTIONS**

# PUMA AW 560/MF II · 660 II

---

The PUMA AW560 II / 660 II / 560MF II models represent the next generation, high-productivity wheel processing turning centers that provide customers with powerful and stable cutting capabilities and high-efficiency chip disposal.

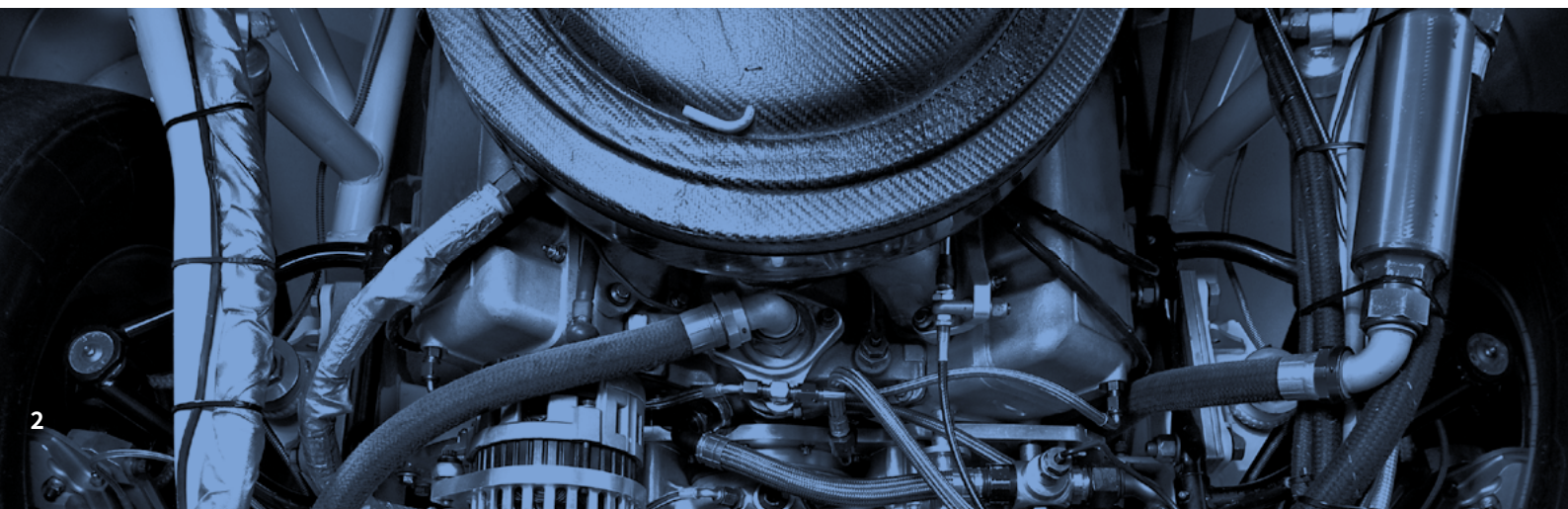



### POWERFUL CUTTING CAPABILITIES AND LARGE MACHINING AREAS

Rigid structures, large envelopes and powerful spindles enable the machining of a wide variety of different-sized aluminum wheels.

### ENHANCED CHIP DISPOSAL AND MAINTENANCE EFFICIENCY

Enhanced chip disposal and efficient lubrication system, and simple maintenance of air units.

### HIGH-SPEED AND HEAVY-DUTY CUTTING CAPABILITIES

The high-power, high-torque spindle enables accurate high-speed machining and heavy-duty machining at low speed to be undertaken.

# BASIC STRUCTURE | MACHINING AREA

The PUMA AW II machines are user-friendly and, in addition to their enhanced cutting capabilities, provide customers with highly efficient chip disposal.

Optimized for the machining of aluminum alloy wheels, PUMA AW II machines, with their anti-vibration structures, deliver high accuracies.

The MF model is capable of producing mirror-like surface finishes with extremely low surface roughness.

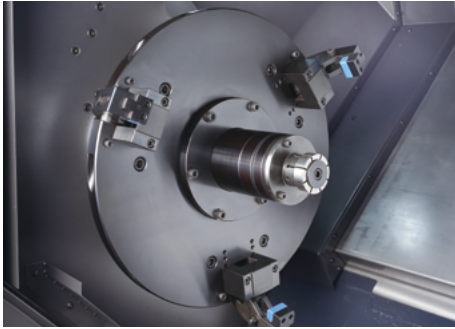
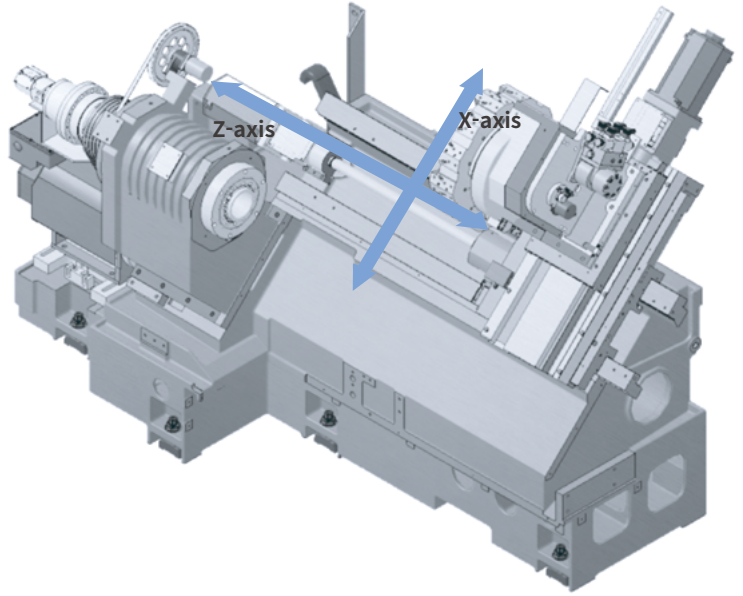

Finger chuck

Description		Unit	AW 560 II	AW 660 II	AW 560MF II
Travel distance	X축	mm (inch)		362 (14.3)	
	Z축	mm (inch)		720 (28.3)	
Rapid traverse rate	X축	m/min (ipm)		16 (629.9)	
	Z축	m/min (ipm)		20 (787.4)	

## MACHINING AREA

The machines in the series have large machining areas for processing a wide variety of aluminum wheel sizes.

### Max. turning diameter

PUMA AW560 II / 560MF II

**Ø550** mm  
21.7 inch

PUMA AW660 II

**Ø650** mm  
25.6 inch

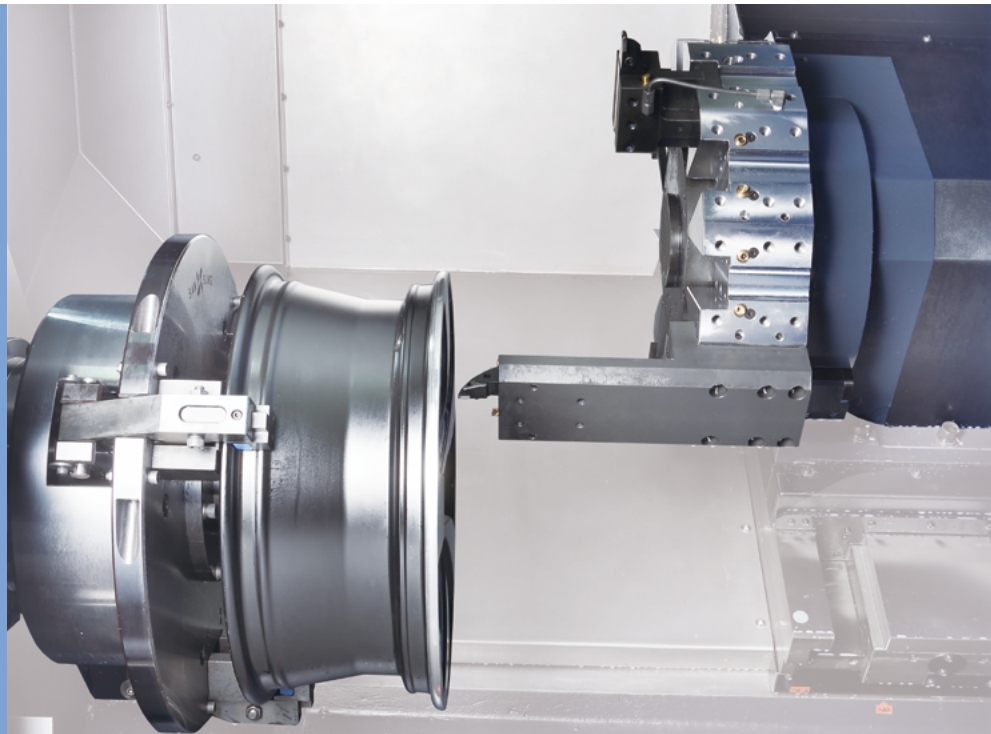

Description	Unit	AW 560 II	AW 660 II	AW 560MF II
Max. turning dia.	mm (inch)	Ø550 (Ø21.7)	Ø650 (Ø25.6)	Ø550 (Ø21.7)
Recommended turning dia.	mm (inch)	508 (20")	610 (24")	508 (20")
Max. turning length	mm (inch)		710 (28.0)	

# SPINDLE | TURRET

The powerful, high-torque spindle provides high accuracy cutting at high speeds and heavy-duty cutting at low speeds. The MF model has a built-in spindle that delivers superior surface finishes.

## Max. turning speed

**2500** r/min

## Max. power (30min/cont.)

**37/30** kW 49.6/40.2 Hp

## Max. Torque

**538** N·m 397.0 ft-lbs

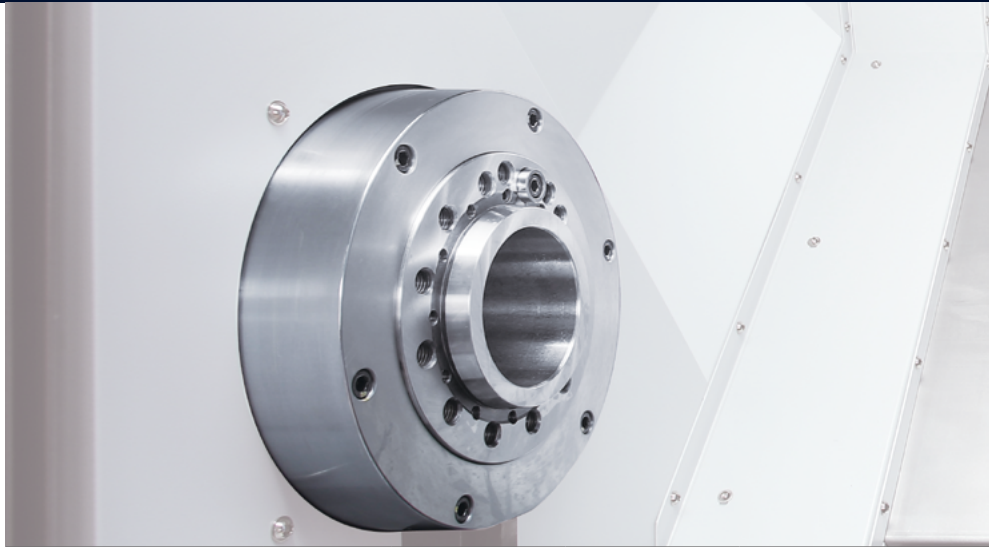

Description	Unit	AW 560 II	AW 660 II	AW 560MF II
Spindle speed	r/min	2500	2000	2500
Spindle power (30min/cont.)	kW (Hp)	37/30 (49.6/40.2)	37/30 (49.6/40.2)	30/25 (40.2/33.5)
Spindle torque	N·m (ft-lbs)	461 (340.2)	538 (397.0)	325 (239.7)
Spindle type	-	Belt drive		Built-in spindle

# TURRET

The large curvic coupling and powerful hydraulic clamp reduce vibrations, extend tool life and guarantee reliable and powerful machining performance.

## Index station

**12** ea

## 1station swivel

**0.25** sec

## 1station index

**0.9** sec

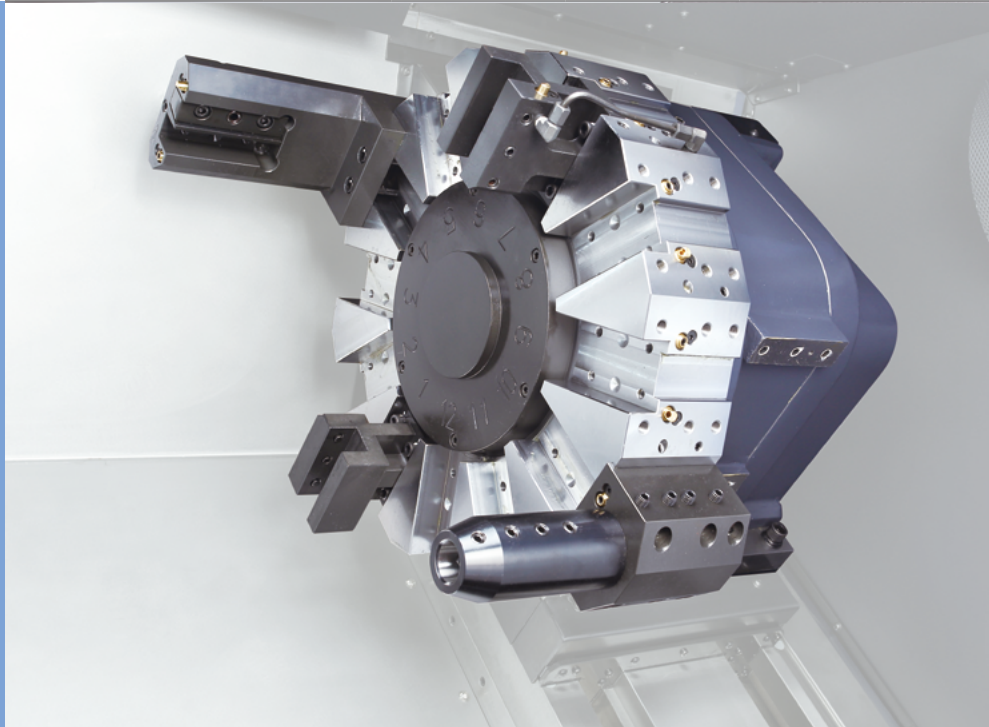

# CHIP DISPOSAL

The streamlined cover with a steep angle removes chips quickly and efficiently. The new machines also deliver improved process reliability and operator convenience.

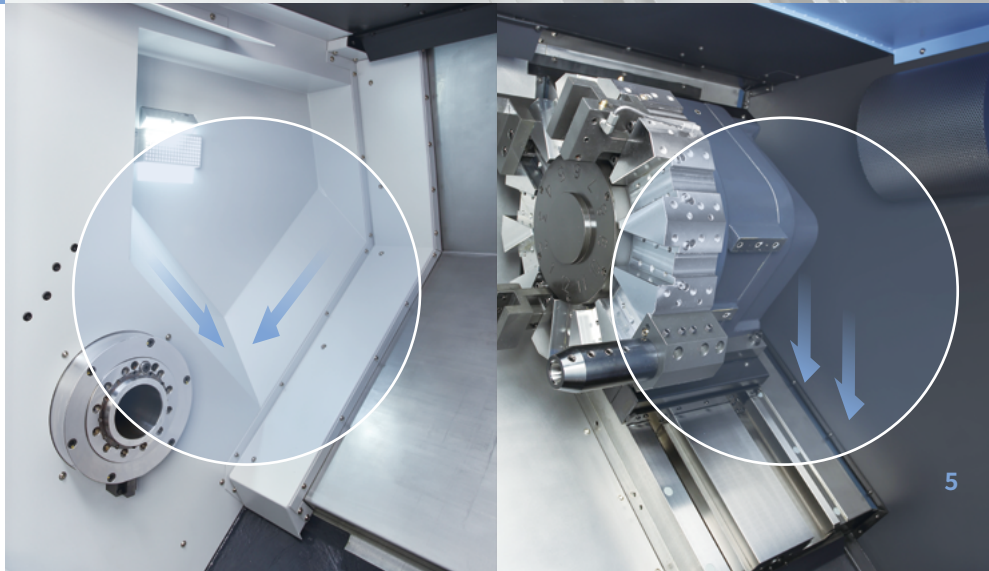

# STANDARD | OPTIONAL SPECIFICATIONS

A range of options is available to suit individual requirements.

Description	Features	PUMA AW II series
Rotary Cylinder	LONG STROKE_Y1240RE	●
	LONG STROKE_Y1550RE	○
Coolant pump	1.1kW_0.7MPa_30L/min	●
	1.1kW_1.0MPa_20L/min	○
	4.0kW_1.45MPa_30L/min	○
Coolant options	High pressure coolant interface	○
	Shower coolant	○
	Oil Skimmer (Belt type)	○
Chip processing	Chip conveyor_Hinged type at right side	○
	Chip conveyor_Magnetic type at right side	○
	Chip bucket_Forklift 220 L (58.1 gallon)	○
	Chip bucket_Forklift 300 L (79.3 gallon)	○
	Chip bucket_Forklift 380 L (100.4 gallon)	○
	Chip bucket_Rotation 220 L (58.1 gallon)	○
	Chip bucket_Rotation 300 L (79.3 gallon)	○
	Chip bucket_Rotation 380 L (100.4 gallon)	○
	Air blower for chuck	○
	Air gun	○
Automatic & Mesurement	Automatic front door and safety devices	○
	Robot interface with PMC I/O module	○
	Robot interface with Profibus DP	○
Optional devices	Tool load mononitoring system	○
	Easy programming guide for PC	○
	Mist collector	○
	Work location confirmation	○
	Chuck clamp confirmation	○
	Auto power off	○
	Work & Tool counter	○
	Signal tower	○
	Electric cabinet light	○
	Air conditioner	○
Quick change tooling(CAPTO)	○	
Customized Special Option	Coolant level switch : Sensing level - Low	○
	Drum Filter Chip Conveyor	○
	Coolant Chiller	○
	Double Cylinder	○
	Holder Interface Work Proof RLP40	○

\* Please contact your DN Solutions representative for detailed machine information.

● Standard ○ Optional X N/A



There is a high risk of fire when using non-water-soluble cutting fluids, processing flammable materials, neglecting the controlled and careful use of coolants and modifying the machine without the consent of the manufacturer. Always check the SAFETY GUIDELINES carefully before using the machine.

# PERIPHERAL EQUIPMENT

## Shower Coolant OPTION

The shower coolant washes workpiece with coolant sprayed from above.

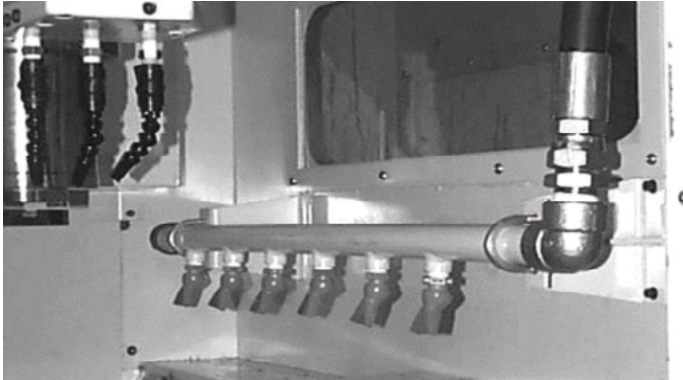

## Oil Skimmer OPTION

The oil skimmer keeps coolant and lubricant isolated from each other to extend the lifecycle of coolant.

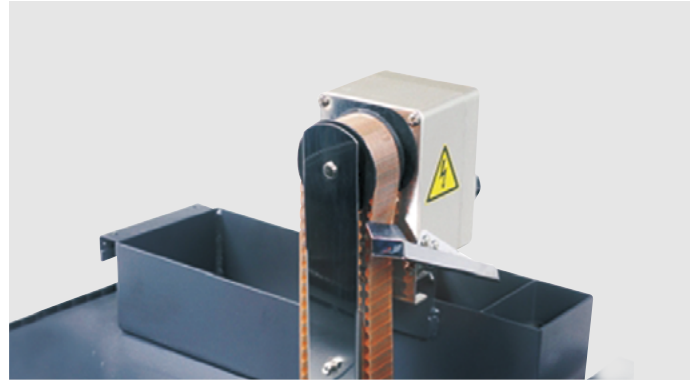

## Chuck Coolant OPTION

The chuck coolant removes chips on the chuck and jaws to facilitate contact between the workpiece and the chuck.

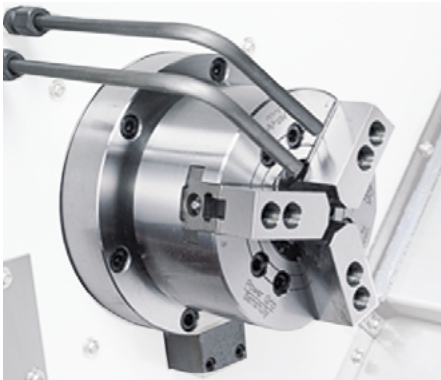

## Coolant chiller (Recommendation) OPTION

Coolant chiller is highly recommended to prevent temperature rise and minimize thermal deformation, when using a water-insoluble coolant or high-pressure coolant system of which the power is over 1.5 kw.

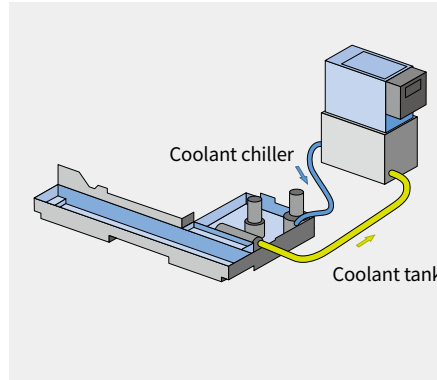

## Quick change CAPTO OPTION

The quick change tool system simplifies tool change operations. Recommended for users who need to change tools frequently or to reduce set-up times.



## Dust Collector OPTION

The dust collector absorbs airborne oil vapor and fine dust in the system to improve working environment.



## Work & Tool Counter OPTION

The counter counts daily and cumulative works, tool usage, etc.



## Power Panel Air Conditioner OPTION

When a machine operates in a hot environment, this device regulates the temperature inside of power panel to prevent the panel from malfunctioning owing to the of temperature fluctuation.



## Signal Tower OPTION

Device to show present statuses of the machine.



# DN SOLUTIONS FANUC i PLUS

DN Solutions Fanuc i Plus maximizes customer productivity and convenience.

## 15" Screen + New OP

DN Solutions Fanuc i Plus' operation panel enhances operating convenience by incorporating common-design buttons and layout. It features a Qwerty keyboard for fast and easy data input and operation.

## DN Solutions Fanuc i Plus

- 15-inch color display
- Intuitive and user-friendly design

## USB and PCMCIA card QWERTY keyboard

- EZ-Guide i standard
- Ergonomic operator panel
- 2MB Memory
- Hot keys



## iHMI touchscreen OPTION

iHMI provides an intuitive interface that uses a touchscreen for quick and easy operation.

## Range of applications

Providing various applications related to planning, machining, improvement and utility, for customer convenience.

# NUMERIC CONTROL SPECIFICATIONS

FANUC

Division	Item	Specifications	AW560/660 II	AW560MF II	AW560/660 II	AW560MF II
			DN Solutions Fanuc i Plus	DN Solutions Fanuc i Plus	Fanuc 32i (F32i-B)	Fanuc 31i (F31i-B)
Controlled axis	Controlled axes		2(X,Z)	2(X,Z)	2(X,Z)	2(X,Z)
	Simultaneously controlled axes		2 axes	2 axes	2 axes	2 axes
Data input/output	Fast data server		○	○	○	○
	Memory card input/output		●	●	●	●
	USB memory input/output		●	●	●	●
	Larger capacity memory_2GB	Note *2) Available Option only with 15" Touch LCD (iHMI Only)	○ *2)	○ *2)	○ *2)	○ *2)
Interface function	Embedded Ethernet		●	●	●	●
	Fast Ethernet		○	○	○	○
	Enhanced Embedded Ethernet function		●	●	●	●
Operation	DNC operation	Included in RS232C interface.	●	●	●	●
	DNC operation with memory card		●	●	●	●
Program input	Workpiece coordinate system	G52 - G59	●	●	●	●
Feed function	AI contour control I	G5.1 Q_, 40 Blocks	○	○	○	○
	AI contour control II	G5.1 Q_, 200 Blocks	○	○	○	○
Operation Guidance Function	EZ Guidei (Conversational Programming Solution)		●	●	●	●
	iHMI with Machining Cycle	Note *1) Only with 15" Touch LCD standard	○ *1)	○ *1)	X	X
	EZ Operation package		●	●	●	●
Setting and display	CNC screen dual display function		●	●	●	●
Network	FANUC MTConnect		⊕	⊕	⊕	⊕
	FANUC OPC UA		⊕	⊕	⊕	⊕
Others	Display unit	15" color LCD	●	●	●	●
	Part program storage size & Number of registerable programs	15" color LCD with Touch Panel	○	○	X	X
		640M(256KB)_500 programs	X	X	●	●
		5120M(2MB)_1000 programs	●	●	○	○

Network: FANUC MTConnect and FANUC OPC UA available.

● Standard ○ Optional X N/A ⊕ Available



# POWER | TORQUE

## PUMA AW 560 II

Max. spindle speed : **2500** r/min

Max. power : **37/30** kW  
34.9 Hp

Max. torque : **461** N·m  
340.2 ft-lbs

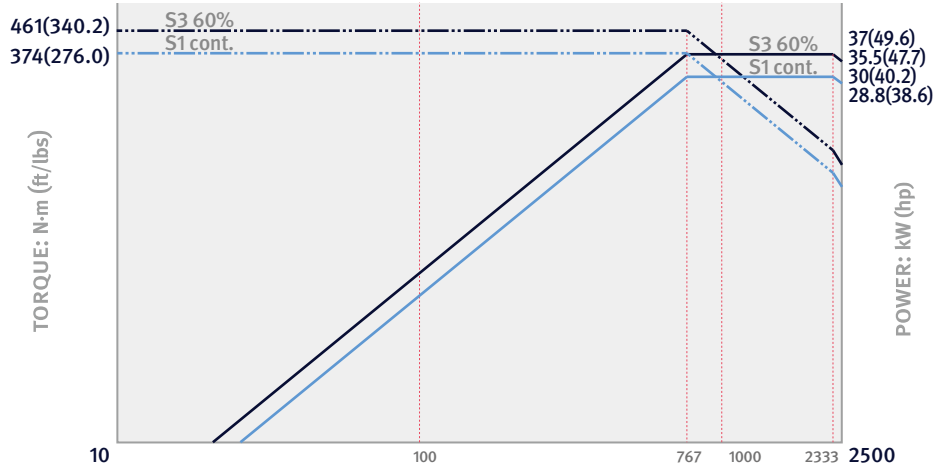

## PUMA AW 660 II

Max. spindle speed : **2000** r/min

Max. power : **37/30** kW  
49.6/40.2 Hp

Max. torque : **538** N·m  
397.0 ft-lbs

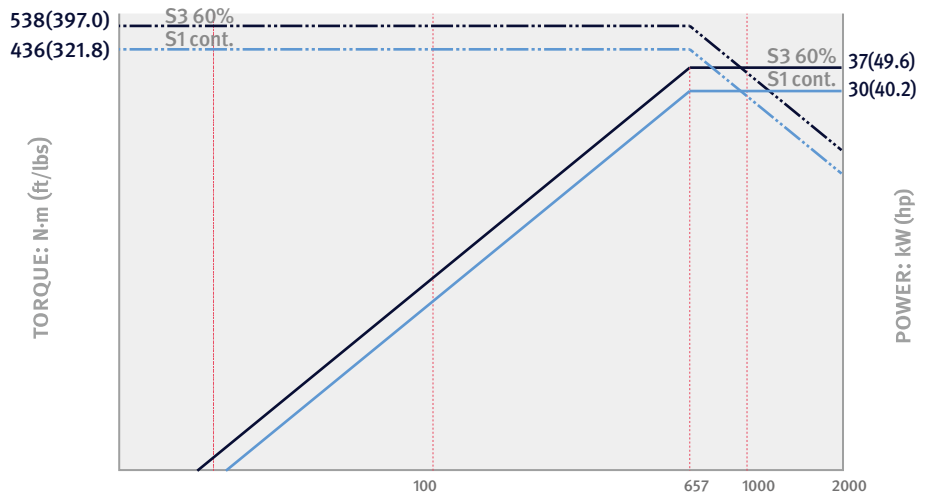

## PUMA AW 560MF II (built-in)

Max. spindle speed : **2500** r/min

Max. power : **30/25** kW  
40.2/33.5 Hp

Max. torque : **699** N·m  
515.9 ft-lbs

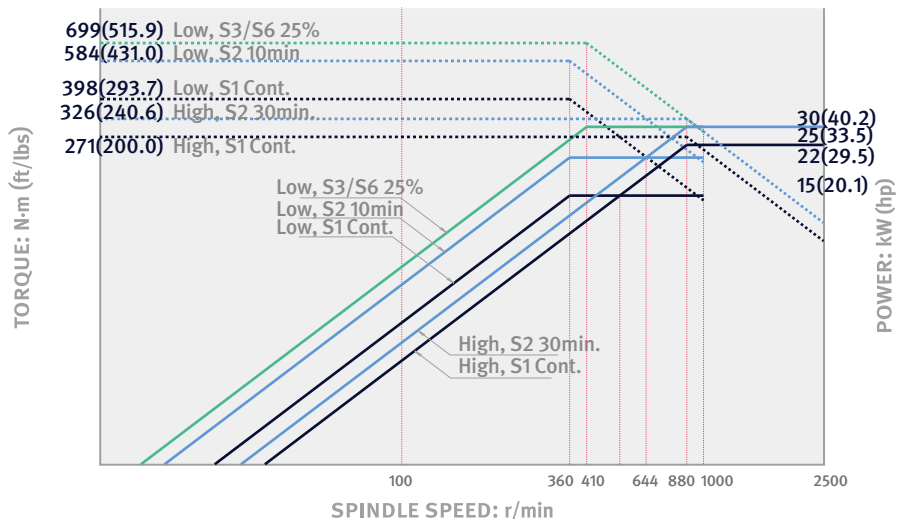

# EXTERNAL DIMENSIONS

PUMA AW560 II / 660 II / 560MF II

Unit : mm (inch)

TOP

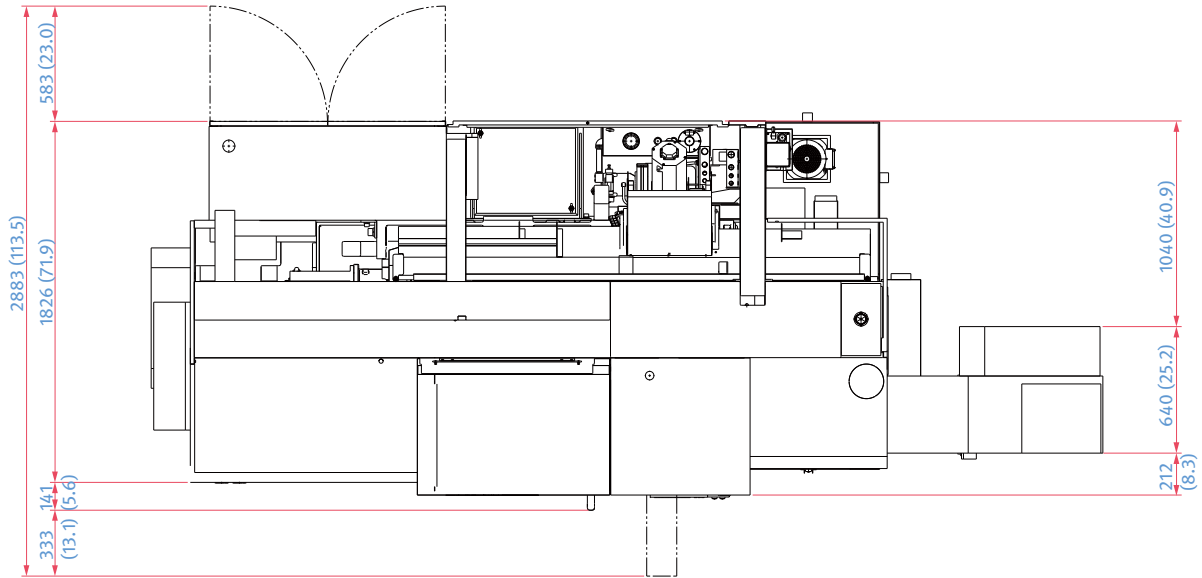

FRONT

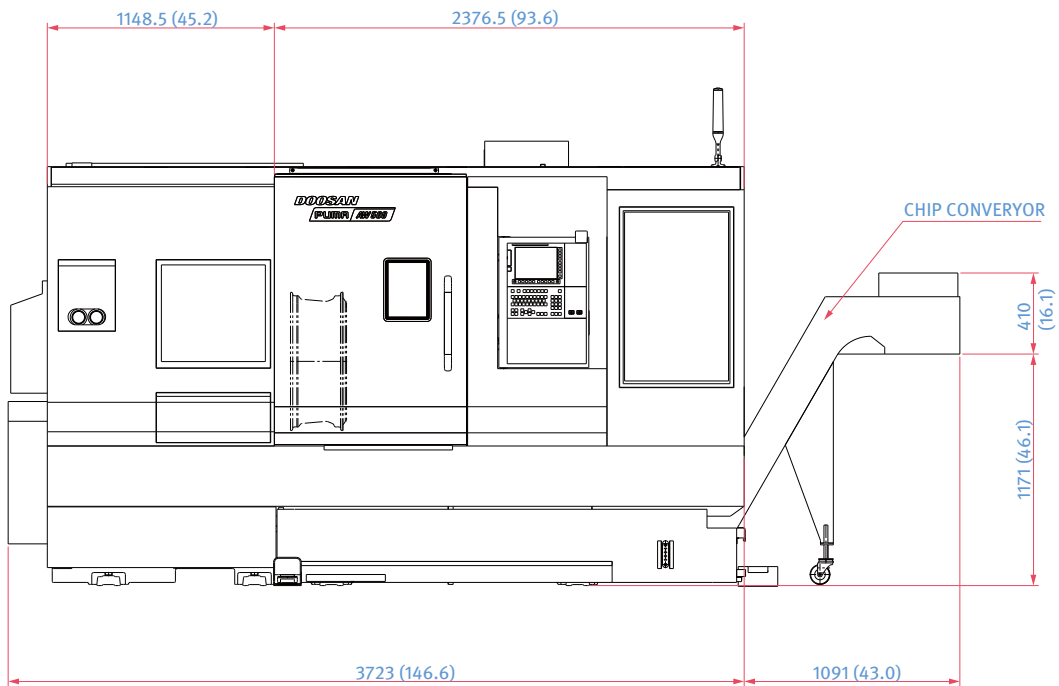

# TOOLING SYSTEM

PUMA AW560 II / 660 II / 560MF II

Unit : mm (inch)

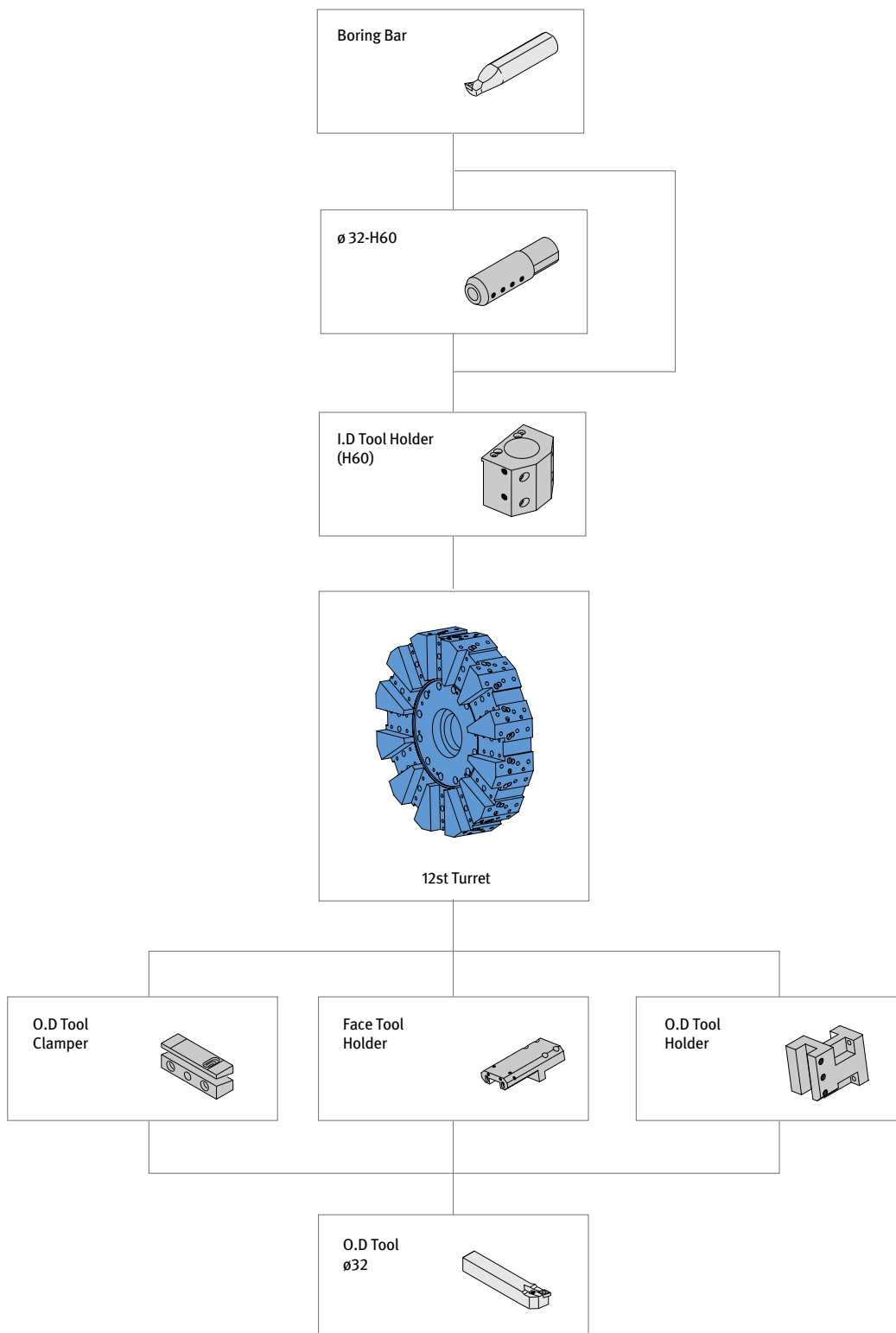

# TOOL INTERFACE

Unit : mm (inch)

## PUMA AW560 II

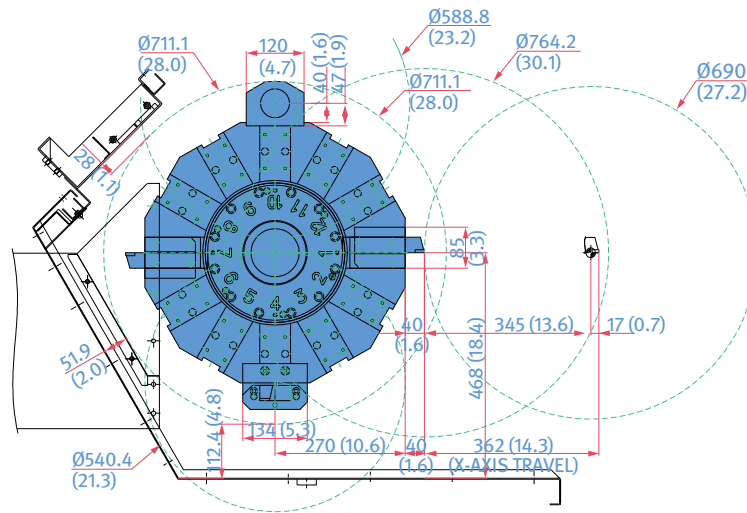

## PUMA AW660 II

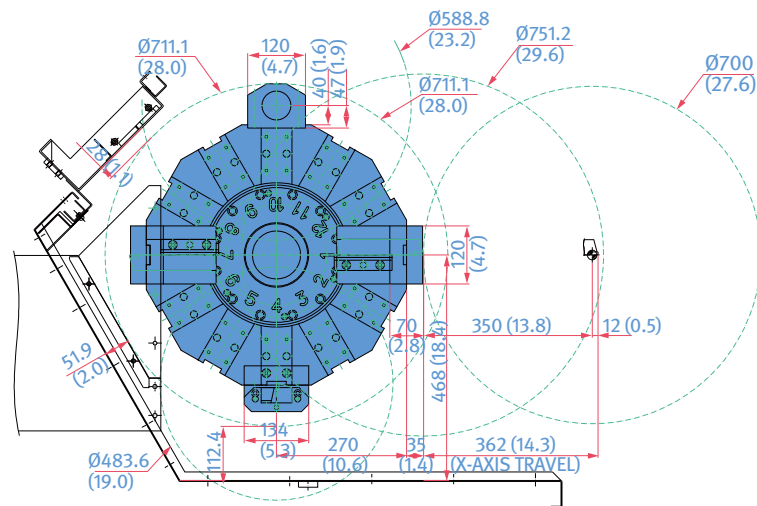

## PUMA AW560MF II

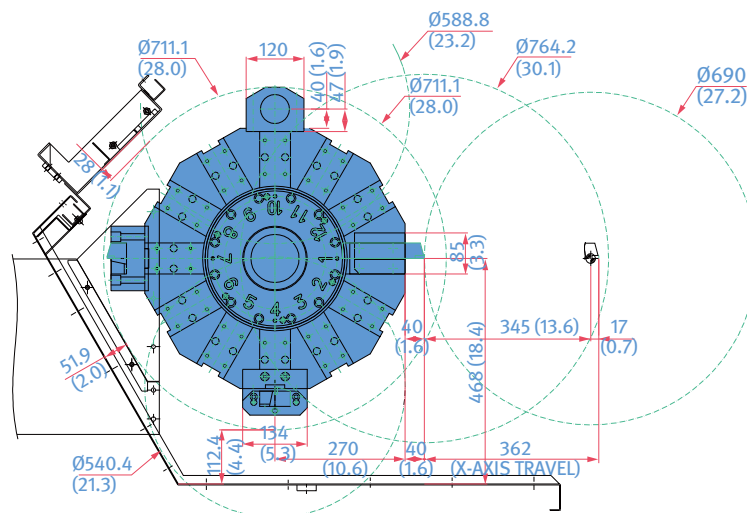

# WORKING RANGE

Unit : mm (inch)

## PUMA AW560/560MF II

### OD TOOL HOLDER

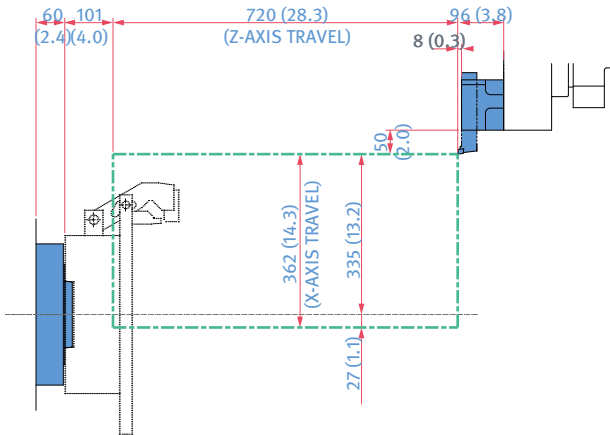

### ID TOOL HOLDER

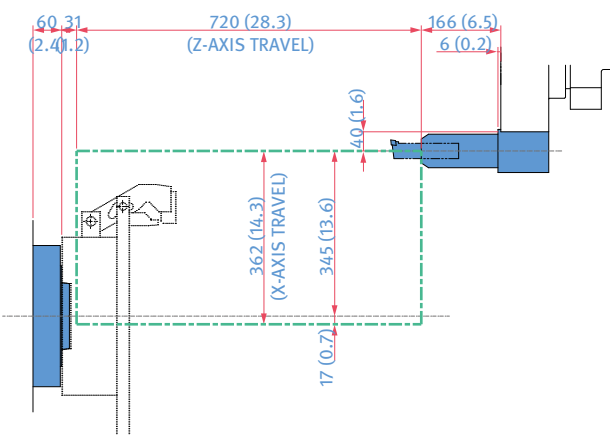

### FACE TOOL HOLDER

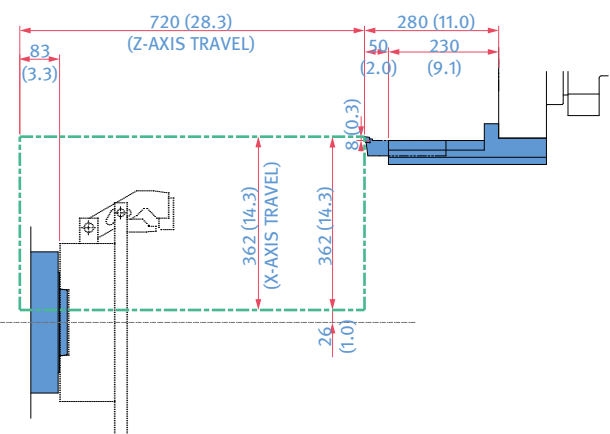

## PUMA AW660 II

### OD TOOL HOLDER

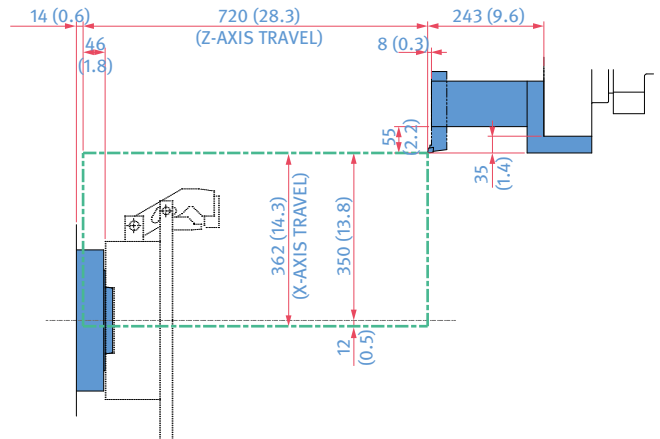

### ID TOOL HOLDER

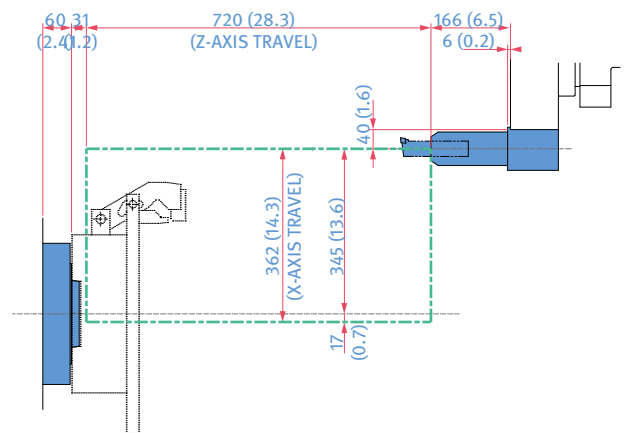

### FACE TOOL HOLDER

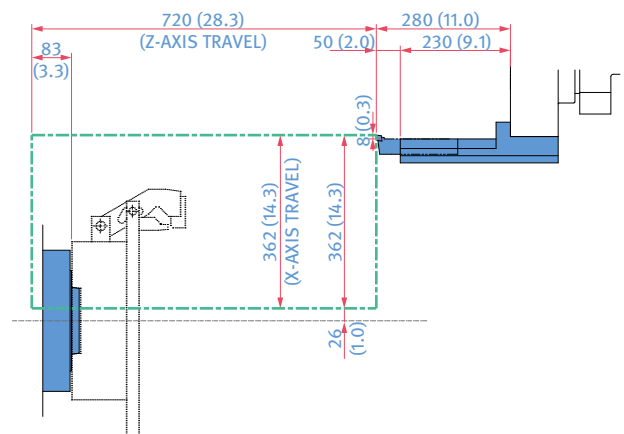

# MACHINE SPECIFICATIONS

PUMA AW II series

Description		Unit	AW 560 II	AW 660 II	AW 560MF II
Capacity	Swing over bed	mm (inch)	830 (32.7)		
	Recommended turning diameter	mm (inch)	508 (20")	610 (24")	508 (20")
	Max. turning diameter	mm (inch)	550 (21.7)	650 (25.6)	550 (21.7)
Travels	Travel distance	X-axis	362 (14.3)		
		Z-axis	720 (28.3)		
Feedrates	Rapid traverse rate	X-axis	16 (629.9)		
		Z-axis	20 (787.4)		
Spindle	Spindle nose	ASA	A2-8	A2-11	A2-8
	Spindle bearing diameter	mm (inch)	160 (6.3)	180 (7.1)	130 (5.1)
	Spindle through hole diameter	mm (inch)	76 (3.0)	86 (3.4)	
	Bore of Draw Tube	mm (inch)	-		45 (1.8)
	Max. spindle power (S3 60% / S1 Cont.)	kW (Hp)	37/30 (49.6/40.2)	37/30 (49.6/40.2)	30/25 (40.2/33.5)
	Max. spindle speed	r/min	2500	2000	2500
	Full Power Range	r/min	767~2333	357~2000	880~2500
	Gear Ratio	-	1 : 1.5	1 : 1.75	1 : 1
	Max. spindle torque	N · m (ft-lbs)	461 (340.2)	538 (397.0)	699 (515.9)
Turret	No. of tool stations	ea	12		
	OD tool size	mm (inch)	32 X 32 (1.3 X 1.3)		
	Max. boring bar size	mm (inch)	Ø60 (2.4)		
	Turret Indexing time (1 station swivel)	sec	0.25		
Power source	Power consumption	kVA	53.08		53.1
Machine Dimensions	Length x Width	mm (inch)	3730 X 2200 (146.9 X 86.6)		
	Height	mm (inch)	2250 (88.6)		
	Weight	kg (lb)	7750 (17085.6)	8000 (17636.7)	7750 (17085.6)
Control	CNC system	-	DN Solutions Fanuc i		Fanuc 31i

# RESPONDING TO CUSTOMERS ANYTIME, ANYWHERE

## DN Solutions Global Network

DN Solutions provides systems-based professional support services, before and after the machine tool sale, by responding quickly and efficiently to customers. By supplying spare parts, product training, field service and technical support, we provide the expert care, attention and assistance our customers expect from a market leader.

Global sales and service support network		<b>51</b>	<b>Technical centers</b> Technical center, Sales support, Service support, Parts support
<b>4</b>	Corporations	<b>200</b>	<b>Service posts</b>
<b>156</b>	Dealer networks	<b>3</b>	<b>Factories</b>



## CUSTOMER SUPPORT AND SERVICES

**We're there for you whenever you need us.**

We help our customers operate at maximum efficiency by providing them with a range of tried, tested and trusted services - from pre-sales consultancy to post-sales support.



### Field services

- On-site service
- Machine installation and testing
- Scheduled preventive maintenance
- Machine repair service



### Parts supply

- Supplying a wide range of original DN Solutions spare parts
- Parts repair service



### Training

- Programming, machine setup and operation
- Electrical and mechanical maintenance
- Applications engineering



### Technical support

- Supports machining methods and technology
- Responds to technical queries
- Provides technical consultancy



[dn-solutions.com](http://dn-solutions.com)

**Head Office**

22F T Tower, 30, Sowol-ro 2-gil  
Jung-gu, Seoul, Korea, 04637

Tel: +82-2-6972-0370/0350  
Fax: +82-2-6972-0400

**DN Solutions America**

19A Chapin Road, Pine Brook  
New Jersey 07058, United States

Tel: +1-973-618-2500  
Fax: +1-973-618-2501

**DN Solutions Europe**

Emdener Strasse 24, D-41540  
Dormagen, Germany

Tel: +49-2133-5067-100  
Fax: +49-2133-5067-111

**DN Solutions India**

No.82, Jakkuar Village  
Yelahanka Hobli, Bangalore-560064

Tel: + 91-80-2205-6900  
E-mail: [india@dncompany.com](mailto:india@dncompany.com)

**DN Solutions China**

Room 101,201,301, Building 39 Xinzhuan  
Highway No.258 Songjiang District  
China Shanghai (201612)

Tel: +86 21-5445-1155  
Fax: +86 21-6405-1472

**Sales inquiry**

[sales@dncompany.com](mailto:sales@dncompany.com)

\* For more details, please contact DN Solutions.

\* Specifications and information contained within this catalogue may be changed without prior notice.